

MAZDA

GB	AUTO DIMMING MIRROR Installation Instruction
D	AUTO-DIMM-SPIEGEL Einbauanleitung
E	ESPEJO CON ATENUACIÓN AUTOMÁTICA Instrucciones de montaje
F	MIROIR DE GRADATION AUTOMATIQUE Instructions de montage
I	SPECCHIO AUTO OSCURAMENTO Istruzioni di montaggio
P	AUTO ESPELHO DE ESCURECIMENTO Instruções de montagem
NL	AUTOMATISCH DIMMENDE BINNENSPIEGEL Inbouw-instructie
DK	AUTOMATISK DÆMPNING SPEJL Monteringsvejledning

N	AUTODIMMING SPEIL Monteringsveiledning
S	AUTOMATISK NEDTONING SPEGEL Monteringsanvisning
SF	AUTOMAATTINEN HIMMENNYS PEILI Asennusohje
CZ	AUTOMATICKÉ STMÍVÁNÍ ZRCADLO Návod k montáži
H	AUTOMATIKUS FÉNYERŐSSÉG TÜKÖR Beszerelési utasítás
PL	LUSTRO AUTOPRZYCIEMNIANIE Instrukcja zabudowy
GR	ΑΥΤΟΜΑΤΟ ΑΧΝΟ ΦΩΤΙΣΜΟ ΚΑΘΡΕΦΤΗ Οδηγίες τοποθέτησης
RUS	АВТОМАТИЧЕСКОЕ ЗАТЕМНЕНИЕ ЗЕРКАЛА инструкция по установке

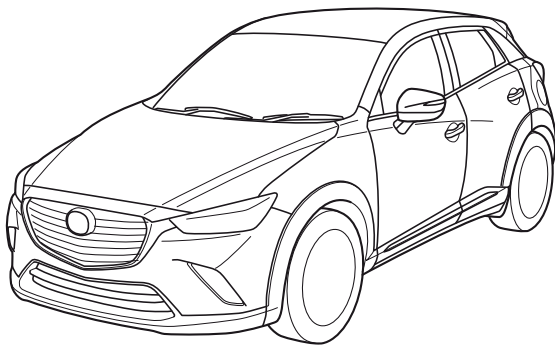

CX-3 DJ1

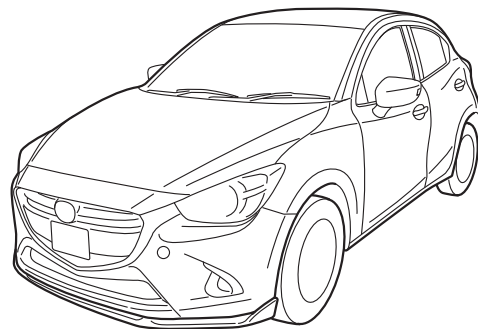

MAZDA 2 DJ1

Part Number: DD2F-V1-740

Date: 20-05-2016

© Copyright MAZDA

Sheet 1 of 16

Expert Fitment Required
Montage durch Fachwerkstatt erforderlich
Montaje sólo por el concesionario
Montage par spécialiste nécessaire
E' necessario in officina specializzata
Especialista em montagem requerido
Montage door vakman nodig
Montage ved professionelt værksted påkrævet
Nødvendig med montering fra fagvejværksted
Verkstadsmontage erfordras
Asennus tarpeen merkkikorjaamossa
Montáž ve specializované dílně nutná
A szereléshez szakműhely kell
Konieczny montaż przez warsztat specjalistyczny
Να τοποθεί απο συνεργείο
Необходима установка специалистами



- (GB) Warning
- (D) Achtung
- (E) Atención
- (F) Attention
- (I) Attenzione
- (P) Atenção
- (NL) Let op
- (DK) Bemærk
- (N) Pass på
- (S) Varning
- (SF) Huomio
- (CZ) Pozor
- (H) Figyelem
- (PL) Uwaga
- (GR) Προσοχή
- (RUS) Осторожно

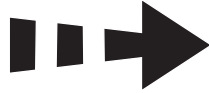

- (GB) Movement Arrow
- (D) Bewegungspfeil
- (E) Flecha de movimiento
- (F) Flèche indiquant sens du mouvement
- (I) Freccia di movimento
- (P) Flexa de movimento
- (NL) Richtingspijl
- (DK) Bevægelsespil
- (N) Bevegelsespil
- (S) Rörelsepil
- (SF) Liikesuuntanuoli
- (CZ) Šipka pohybu
- (H) Mozgásirányjelző nyíl
- (PL) Strzałka kierunku ruchu
- (GR) Βέλος κίνησης
- (RUS) Стрелка по направлению



- (GB) Disconnect
- (D) Abklemmen
- (E) Desconectar
- (F) Déconnecter
- (I) Staccare
- (P) Desligar
- (NL) Demonteren
- (DK) Frakobles
- (N) Klem av
- (S) Koppla los
- (SF) Irrota
- (CZ) Odpojit
- (H) Szakítsa meg, kapcsolja szét
- (PL) Rozłączyć
- (GR) Αποσύνδεση
- (RUS) Разъедините

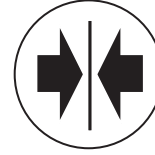

- (GB) Connect
- (D) Verbinden
- (E) Conectar
- (F) Connecter
- (I) Collegare
- (P) Ligar
- (NL) In elkaar
- (DK) Kobles
- (N) Tilkopling
- (S) Ansult
- (SF) Yhdistä
- (CZ) Spojit
- (H) Kapcsolja össze
- (PL) Połączyć
- (GR) Σύνδεση
- (RUS) Соедините

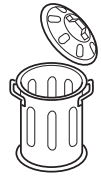

- (GB) Throw away
- (D) Entsorgen
- (E) Tratamiento de residuos
- (F) Jeter aux déchets
- (I) Smaltire
- (P) Eliminar
- (NL) Weggooien
- (DK) Affald
- (N) Avskaffe
- (S) Ta hand om avfallet
- (SF) Hävittää
- (CZ) Vyhodit
- (H) Távolítsa el
- (PL) Usunąć jako odpad
- (GR) Απώσυρση
- (RUS) Выбросите



- (GB) See Workshop Manual
- (D) Siehe Werkstatthandbuch
- (E) Ver manual de taller
- (F) Voir Manuel d'atelier
- (I) Vedere manuale officina
- (P) Cf. o manual da oficina
- (NL) Zie werkplaatshandboek
- (DK) Se værkstedshåndbog
- (N) Se verkstedshåndboka
- (S) Se verkstadshandboken
- (SF) Katso korjaamon käsikirjasta
- (CZ) Viz dilenskou příručku
- (H) Lásd a Műhely-kézikönyvből
- (PL) Patrz podręcznik warsztatowy
- (GR) λέπε Εγχειρίδιο Συνεργείου
- (RUS) Смотрите руководство для мастерской



- (GB) don't use force
- (D) keine Gewalt anwenden
- (E) no utilice la fuerza
- (F) ne pas utiliser la force
- (I) non usare la forza
- (P) não use força
- (NL) geen geweld gebruiken
- (DK) ikke bruge magt
- (N) Ikke bruk makt
- (S) inte använda våld
- (SF) Älä käytä voimaa
- (CZ) nepoužívat sílu
- (H) ne erőltesse
- (PL) nie używaj siły
- (GR) δεν χρησιμοποιούν βία
- (RUS) не применять силу

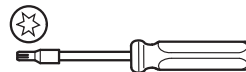

- (GB) Torx
- (D) Torx
- (E) Torx
- (F) Torx
- (I) Torx
- (P) Torx
- (NL) Torx
- (DK) Torx
- (N) Torx
- (S) Torx
- (SF) Torx
- (CZ) Torx
- (H) Torx
- (PL) Torx
- (GR) Torx
- (RUS) Torx



CLEANER

- (GB) Wipe clean
- (D) Reinigen
- (E) Limpiar
- (F) Nettoyer
- (I) Ripulire
- (P) Limpiar
- (NL) Zuiver maken
- (DK) Aftørring
- (N) Rengjøring
- (S) Rengör
- (SF) Puhdista
- (CZ) Očistit
- (H) Tisztítsa meg
- (PL) Oczyszczyć
- (GR) Καθάρισμα
- (RUS) Протрите дочиста

DD2F-V1-740

A

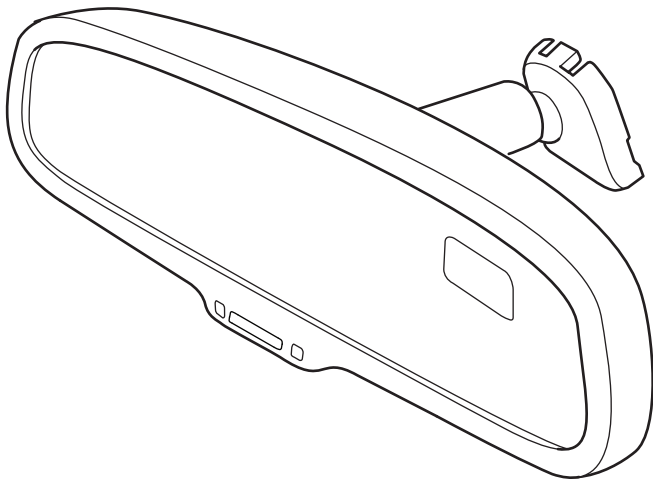

1x

B

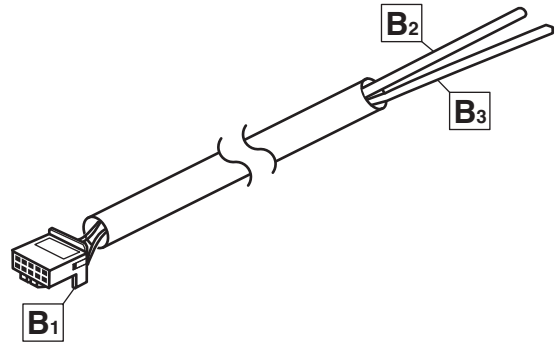

1x

C

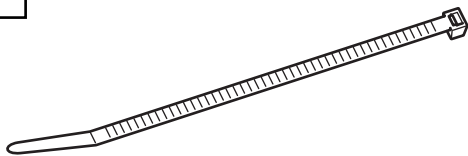

10x

D

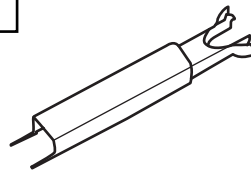

1x

E

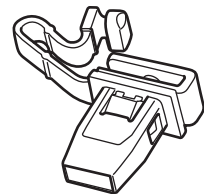

1x

F

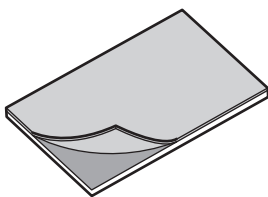

3x

G

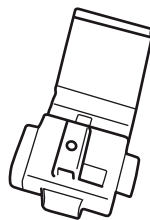

3x

H

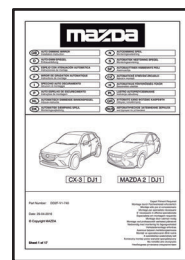

1x

J

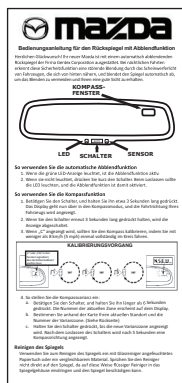

1x

Mazda Color Table

	GB	D	E	F	I	P	NL	DK
B	Black	Schwarz	Negro	Noir	Nero	Preto	Zwart	Sort
BE	Beige	Beige	Beige	Beige	Beige	Bege	Beige	Beige
BR	Brown	Braun	Marrón	Marron	Marrone	Castanho	Bruin	Brun
DG	Dark green	Dunkelgrün	Verde oscuro	Vert foncé	Verde scuro	Verde-escuro	Donkergroen	Mørkegrøn
DL	Dark blue	Dunkelblau	Azul oscuro	Bleu foncé	Blu scuro	Azul-escuro	Donkerblauw	Mørkeblå
G	Green	Grün	Verde	Vert	Verde	Verde	Greon	Grøn
GY	Grey	Grau	Gris	Gris	Grigio	Cinzeno	Grijs	Grå
L	Blue	Blau	Azul	Bleu	Blu	Azul	Blauw	Blå
LB	Light blue	Hellblau	Azul claro	Bleu clair	Blu chiaro	Azul-claro	Lichtblauw	Lyseblå
LG	Light green	Hellgrün	Verde claro	Vert clair	Verde chiaro	Verde-claro	Lichtgroen	Lysegrøn
N	Natural colour	Naturfarbe	Color natural	Nature	Colori naturali	Cores naturais	Naturel	Naturfarvet
O	Orange	Orange	Naranja	Orange	Arancione	Laranja	Oranje	Orange
P	Pink	Rosa	Rosa	Rose	Rosa	Rosa	Rosé	Rosa
PU	Purple	Purpur	Púrpura	Pourpre	Rosso porpora	Púrpura	Paars	Purpur
R	Red	Rot	Rojo	Rouge	Rosso	Vermelho	Rood	Rød
SB	Sky blue	Himmelblau	Azul cielo	Bleu ciel	Celeste	Azul-céu	Hemelsblauw	Himmelblå
T	Yellow brown	Gelbbraun	Amarillo-marrón	Marron-jaune	Giallomarrone	Castanho-amarelado	Geelbruin	Gulbrun
V	Violet	Violett	Violeta	Violet	Viola	Violeta	Violet	Violet
W	White	Weiß	Bianco	Blanc	Bianco	Branco	Wit	Hvid
Y	Yellow	Gelb	Amarillo	Jaune	Giallo	Amarelo	Geel	Gul

	N	S	SF	CZ	H	PL	GR	RUS
B	Sort	Svart	Musta	Černá	Fekete	Czarna	Μαύρο	Чёрный
BE	Beige	Beige	Beige	Beige	béžový	beżowy	Μπεζ	бежевый
BR	Brun	Brun	Ruskea	Hnědá	Barna	Brązowa	Καφέ	Коричневый
DG	Mørkegrønn	Mörkgrön	Tummanvihreä	Tmavozelená	Sötétzöld	Ciemnozielona	Σκούρο πράσινο	Тёмно-зелёный
DL	Mørkeblå	Mörkblå	Tummansininen	Tmavomodrá	Sötétkék	Granatowa	Σκούρο μπλε	Тёмно-синий
G	Grønn	Grön	Vihreä	Zelená	Zöld	Zielona	Πράσινο	Зелёный
GY	Grå	Grå	Harmaa	Šedá	Szürke	Szara	Γκρι	Серый
L	Blå	Blå	Sininen	Modrá	Kék	Niebieska	Μπλε	Синий
LB	Lyseblå	Ljusblå	Vaaleansininen	Bleděmodrá	Világoskék	Jasnoniebieska	Ανοικτό μπλε	Голубой
LG	Lysegrønn	Ljusgrön	Vaaleanvihreä	Světlezelená	Világoszöld	Jasnozielona	Ανοικτό πράσινο	Светло-зелёный
N	Naturfarger	Naturfärger	Luonnonväri	Přírodní barva	Természetes színű	Barwy naturalne	Φυσικά χρωτακάλι	Телесный
O	Orange	Orange	Oranssi	Oranžová	Narancs	Pomarańczowa	Πορφυρό	Оранжевый
P	Rosa	Rosa	Rosa	Růžová	Rózsaszín	Różowa	Ροζ	Розовый
PU	Purpur	Pur Pur	PurPurra	Purpurová	Bíborvörös	Purpurowa	Πορφυρό	Пурпурный
R	Rød	Röd	Punainen	Červená	Piros	Czerwona	Κόκκινο	Красный
SB	Himmelblå	Himmelsblå	Taivaansininen	Blankytá	Égszínkék	Bękitna	Γαλάζιο	Небесно-голубой
T	Gulbrun	Gulbrun	Keltaisenruskea	Žlutohnědá	Sárgásbarna	Żółtobrązowa	Κίτρινοκαφέ	Жёлто-коричневый
V	Fiolett	Violett	Violett	Fialová	lbolyakék	Fioletowa	Μοβν	ФиФиолетовый
W	Hvid	Vit	Valkionen	Bílá	Fehér	Biała	Λευκό	Белый
Y	Gul	Gul	Keltainen	Žlutá	Sárga	Żółta	Κίτρινο	Жёлтый

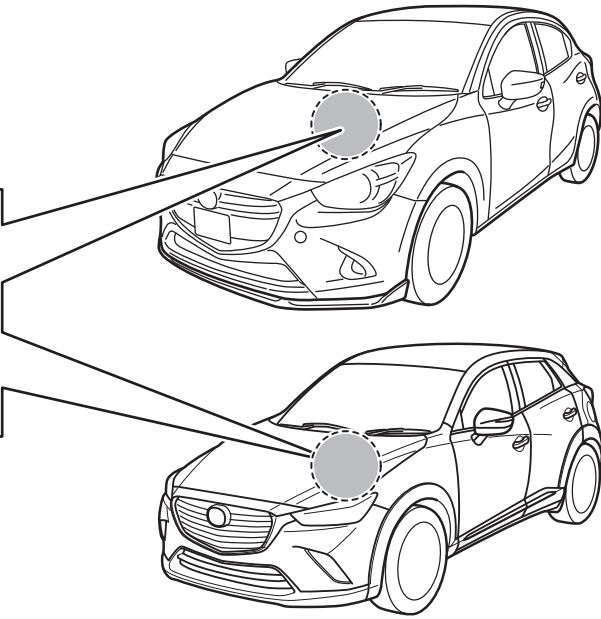
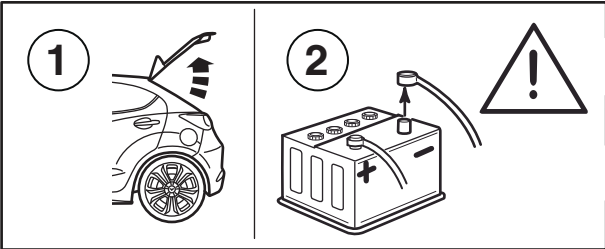
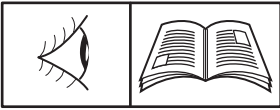

1

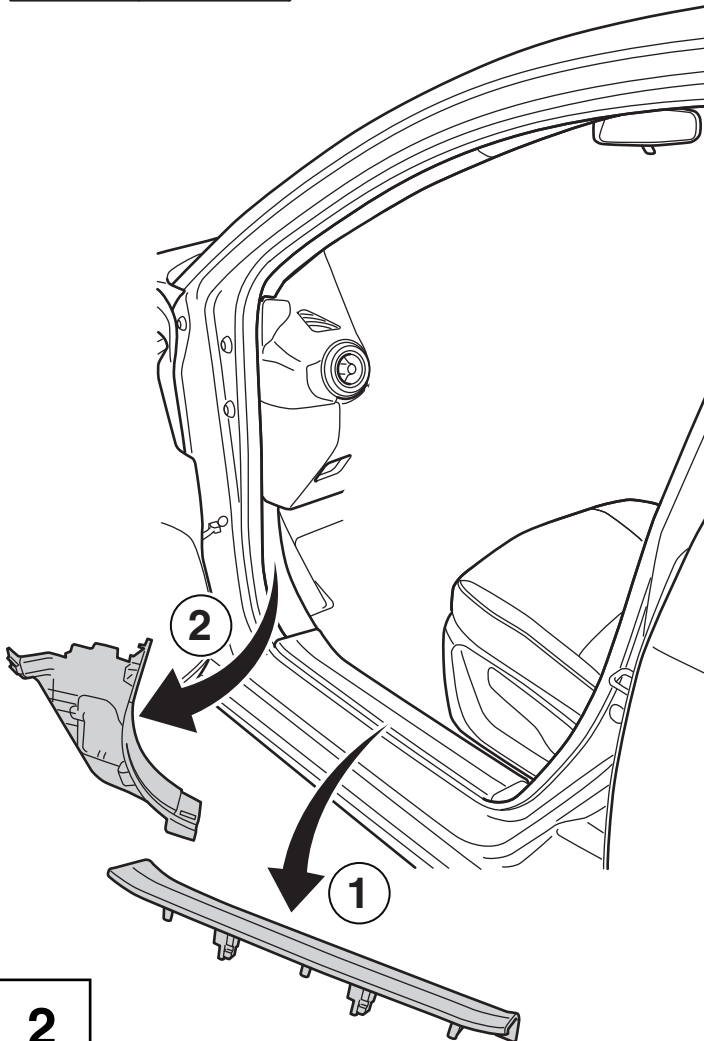

2

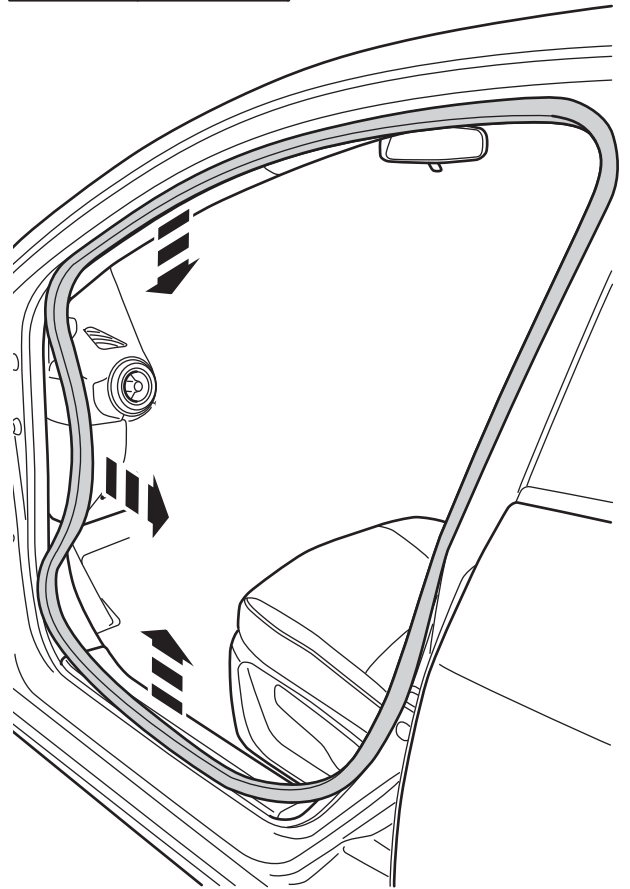

3

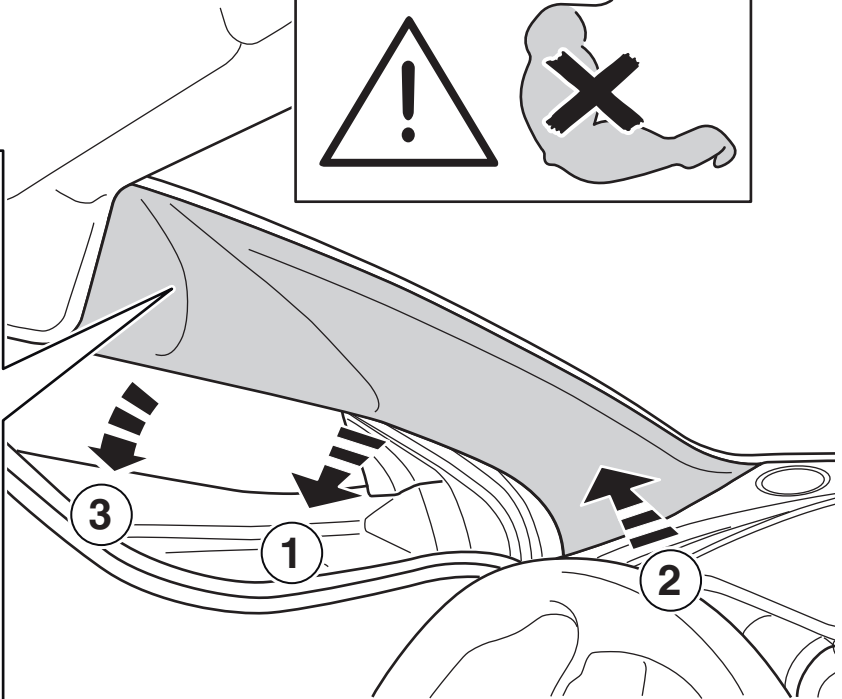
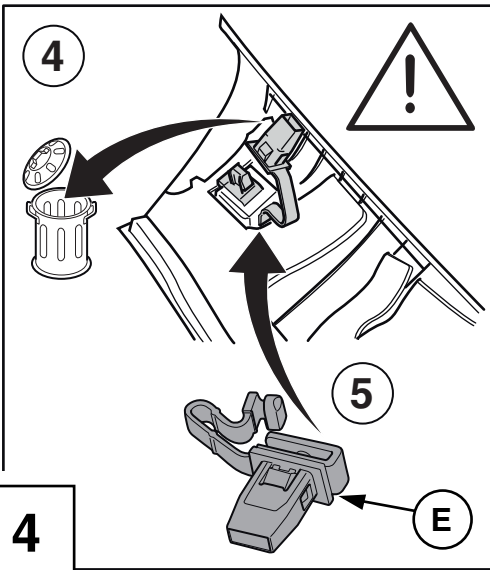
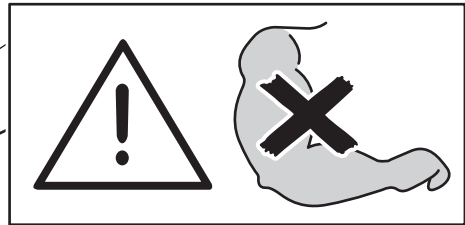
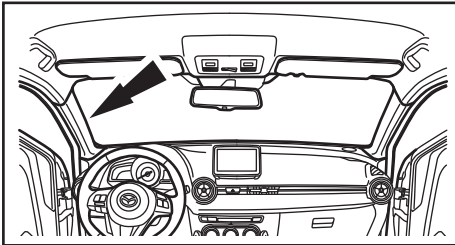

4

i
Info

 **WITH Sensor Cover**

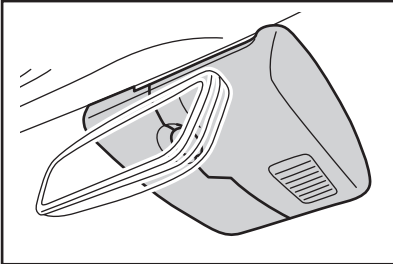

 5 → 9

 **WITHOUT Sensor Cover**

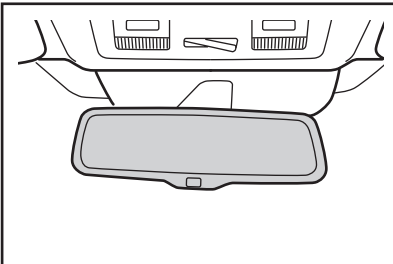

 10 → 13

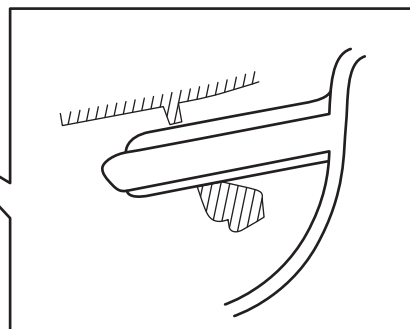
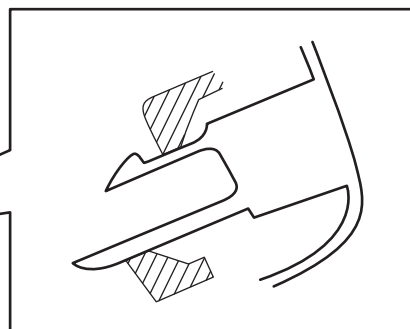
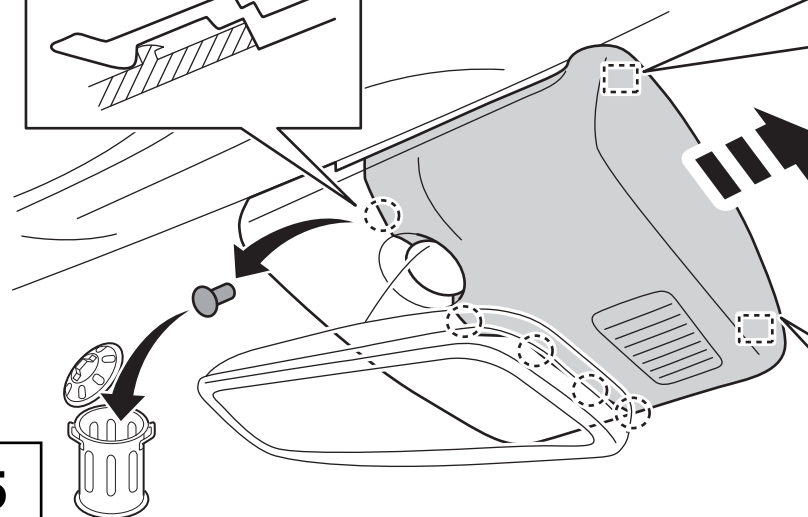
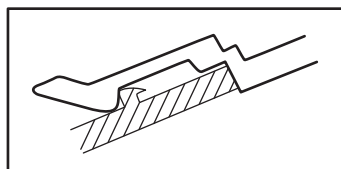

5

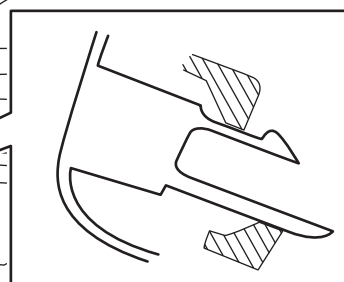
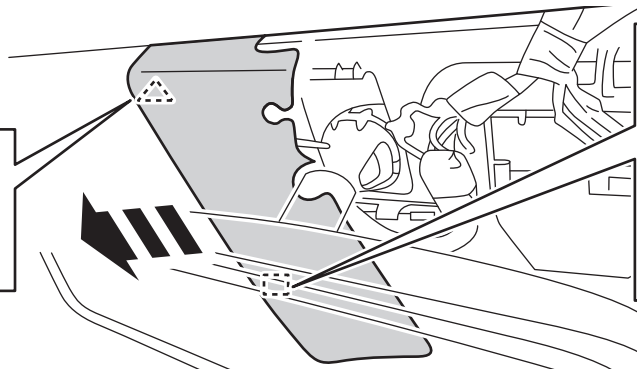
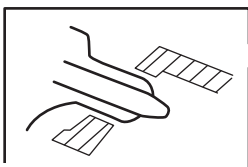

6

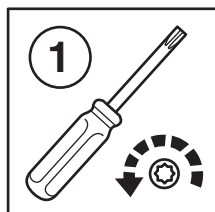

X1

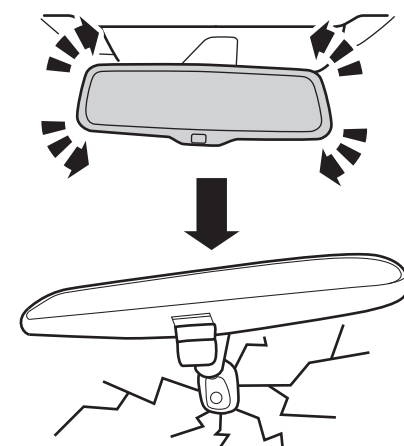
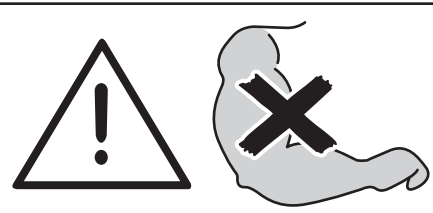
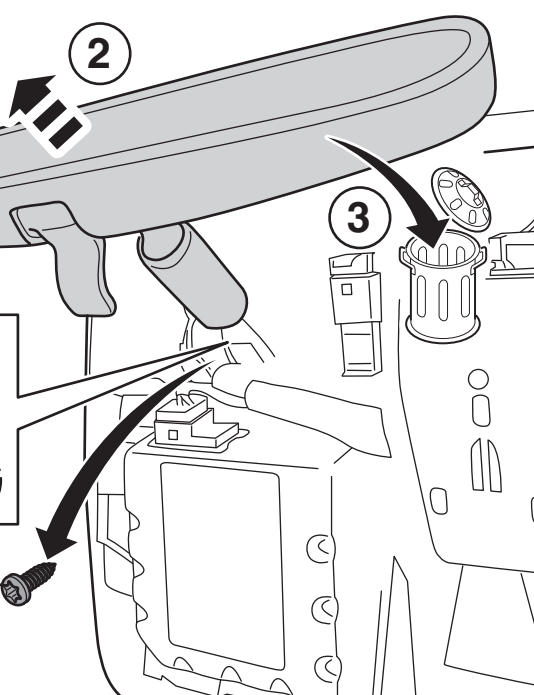

7

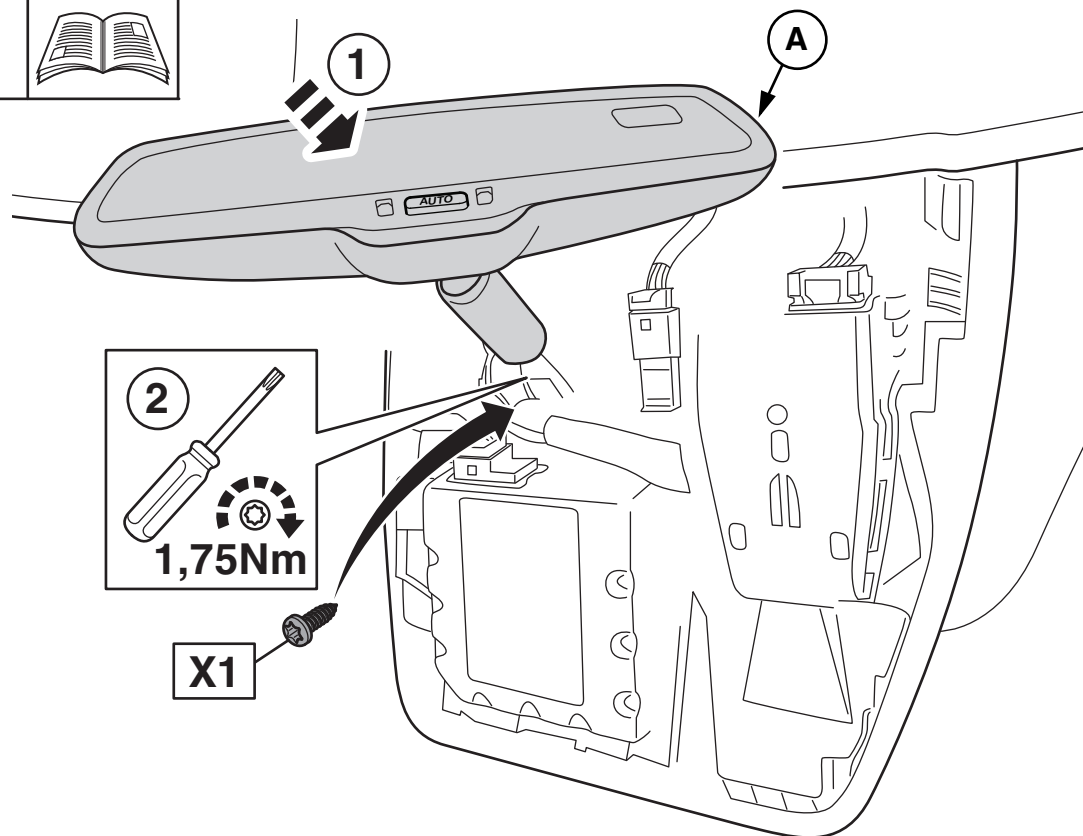

8

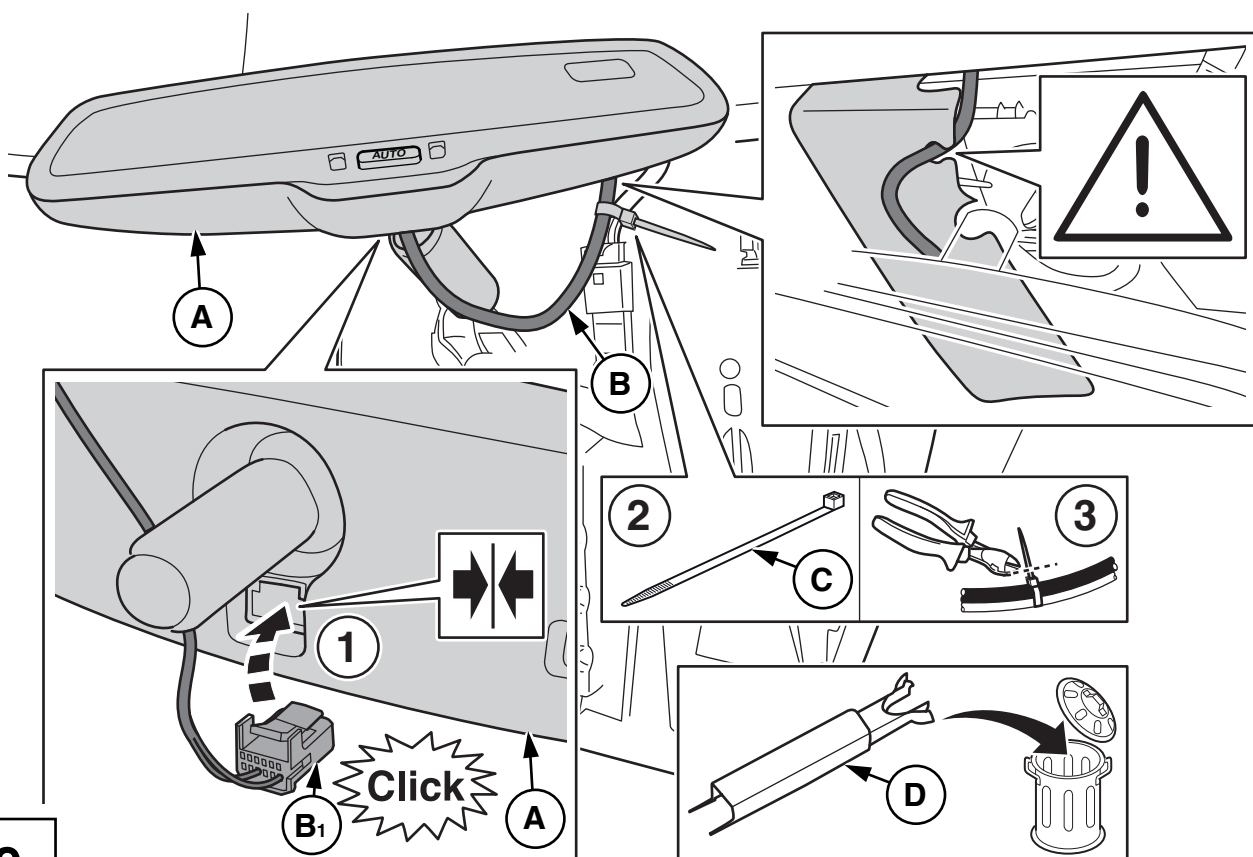

9

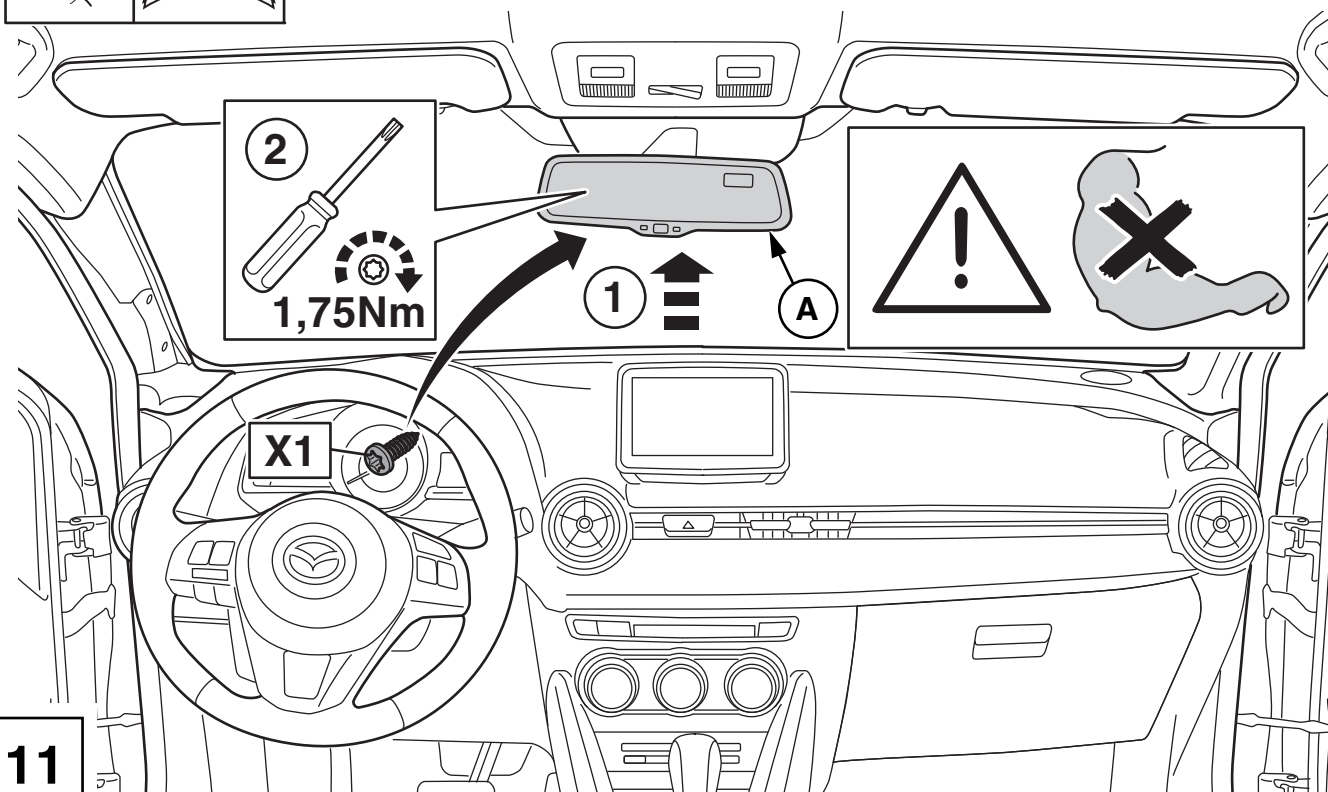
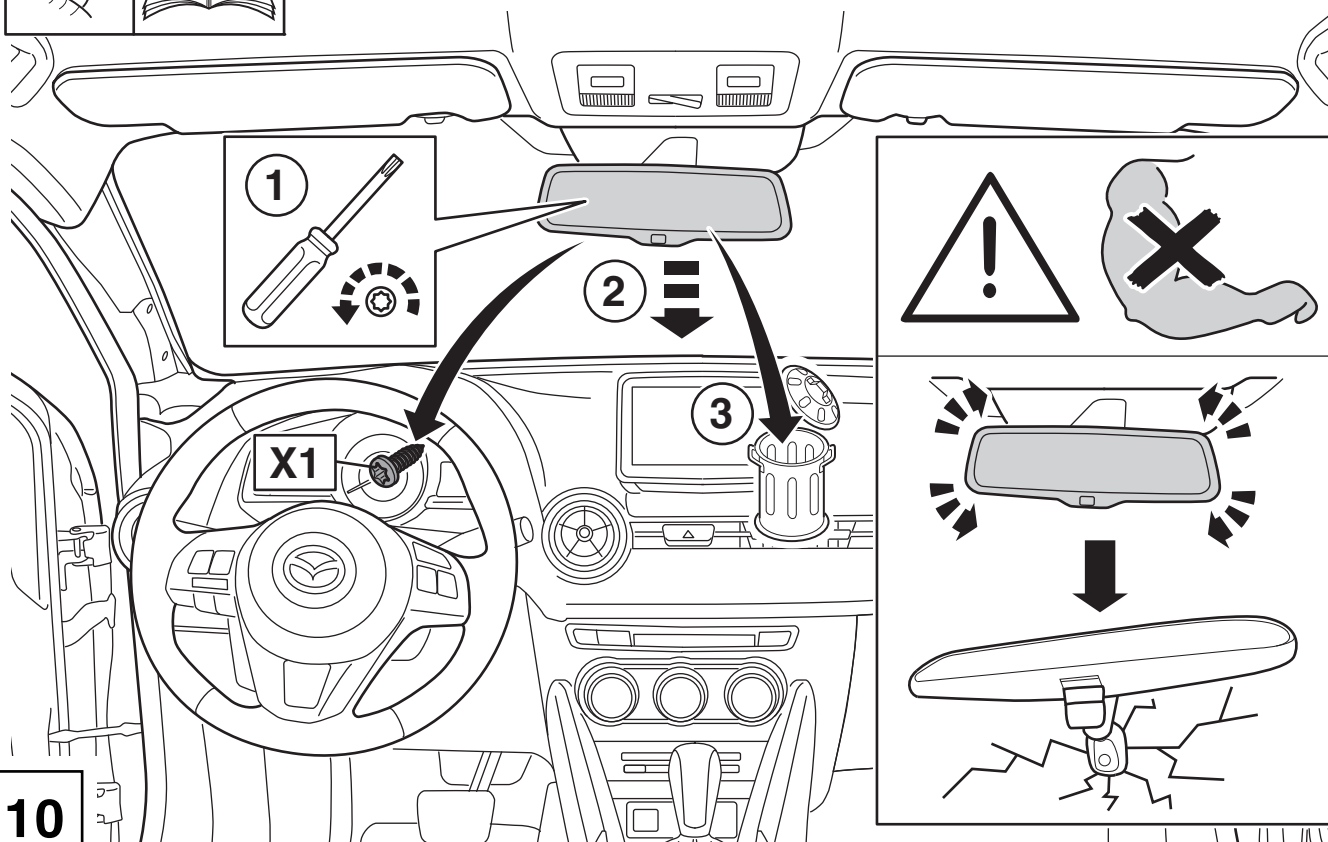

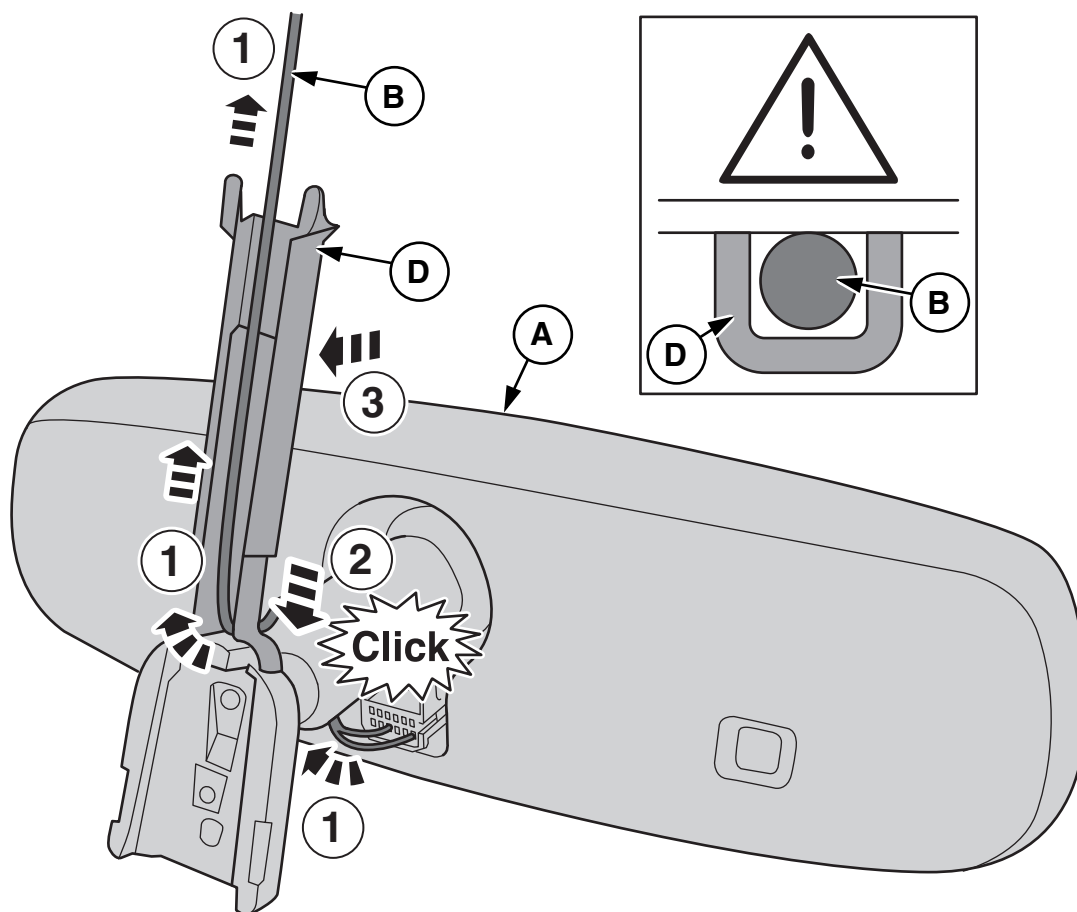
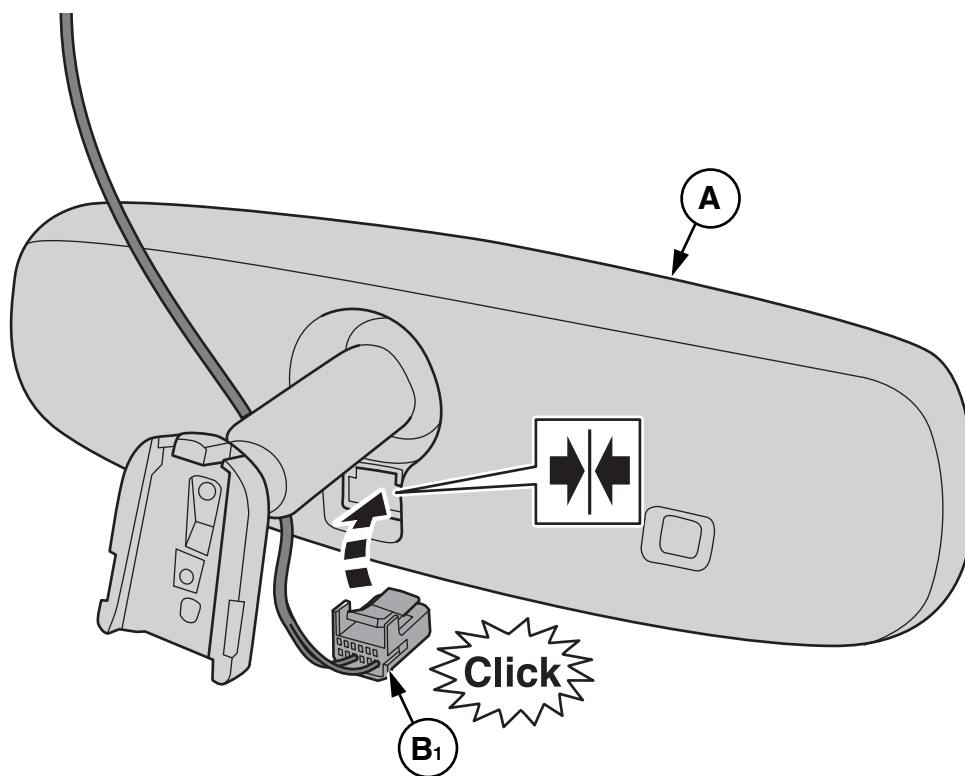

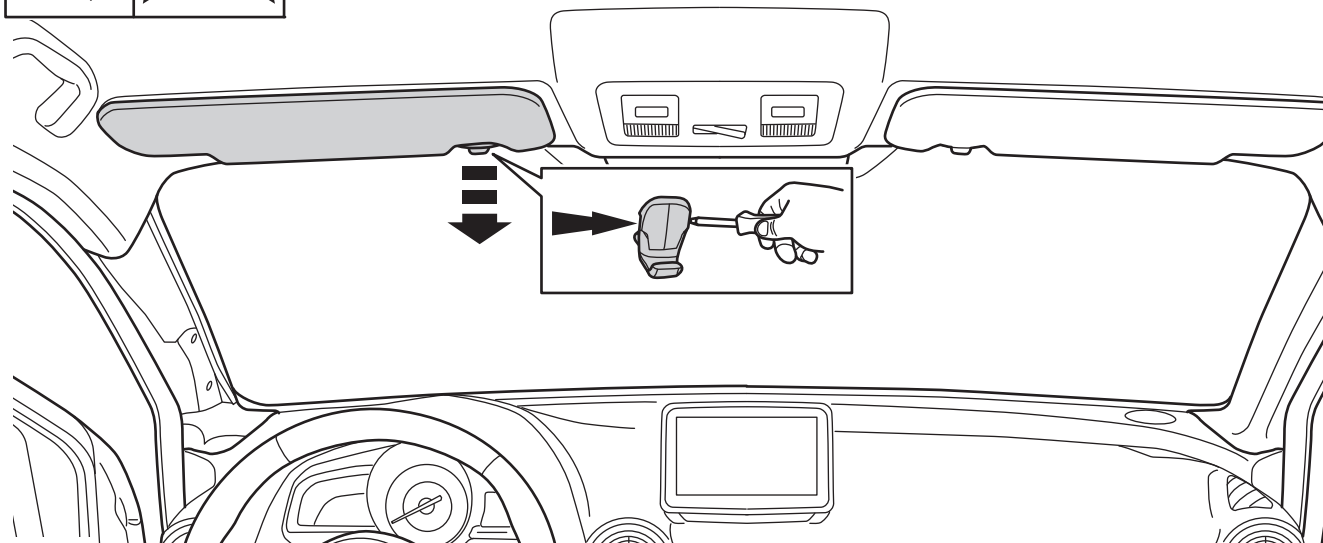

14

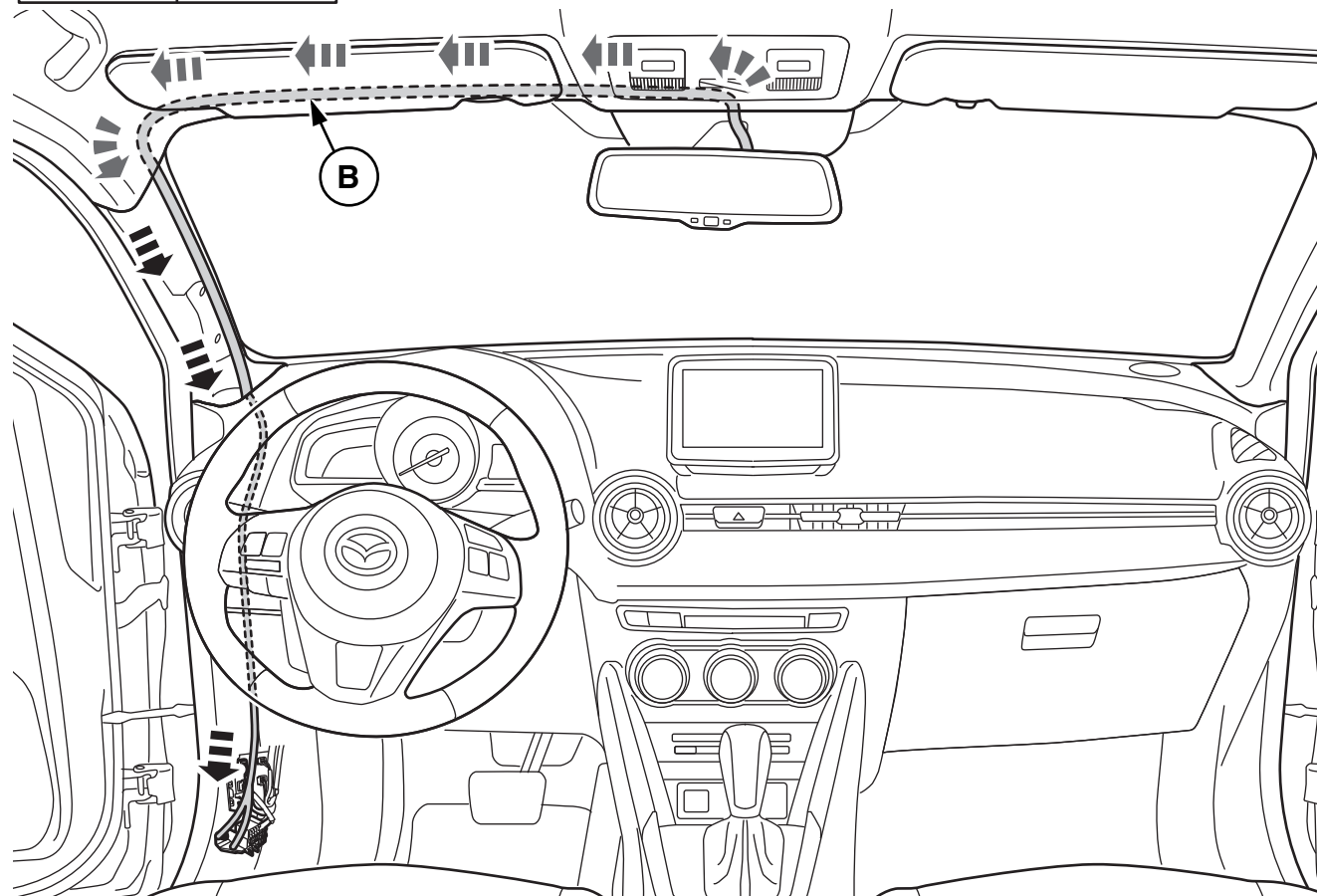
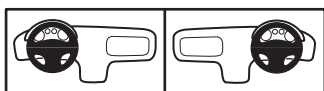

15



WITH OE harness

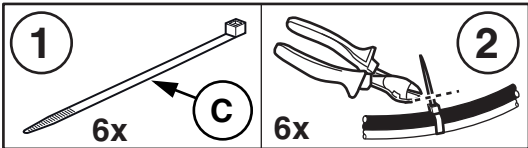
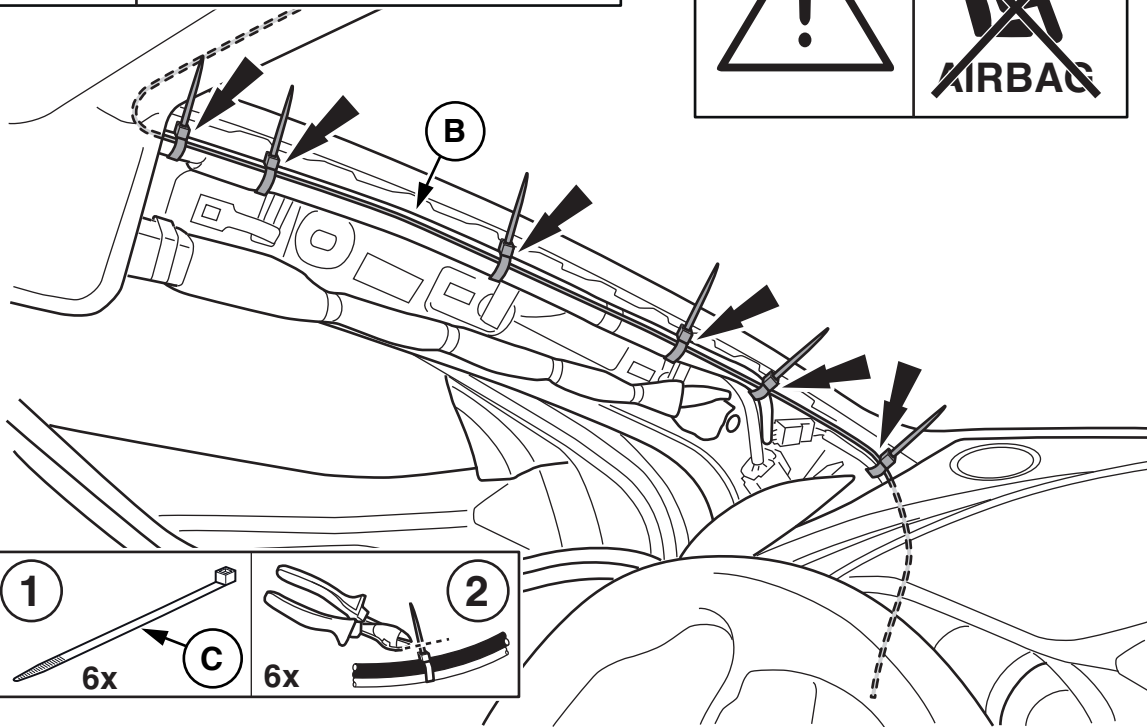

WITHOUT OE harness

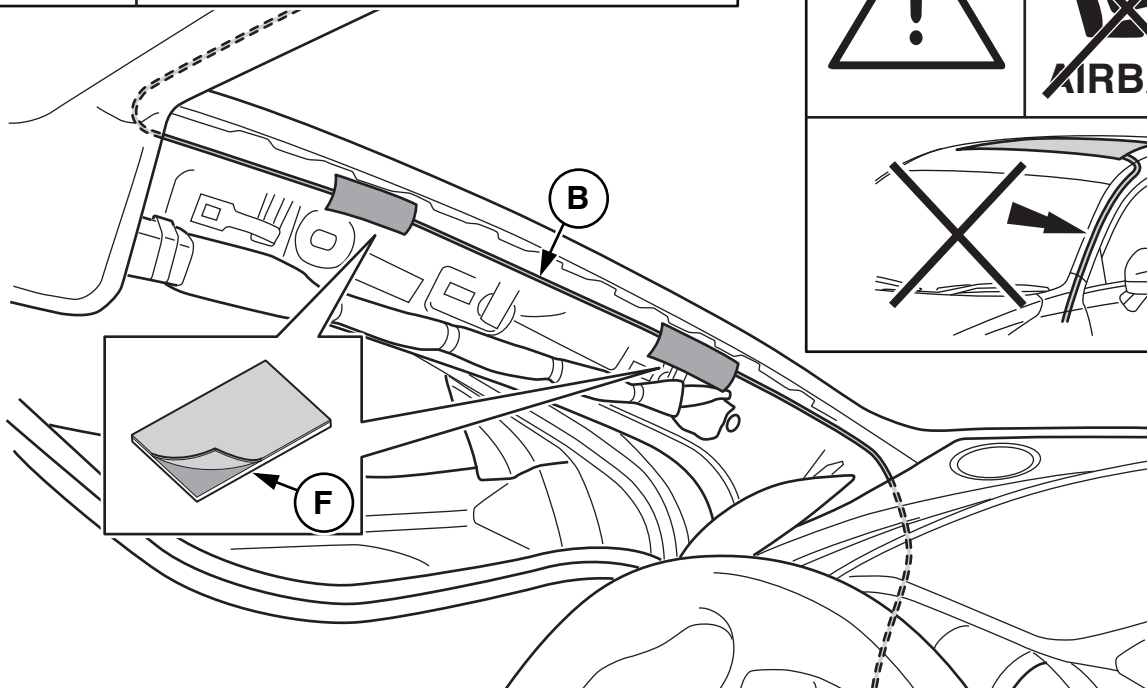
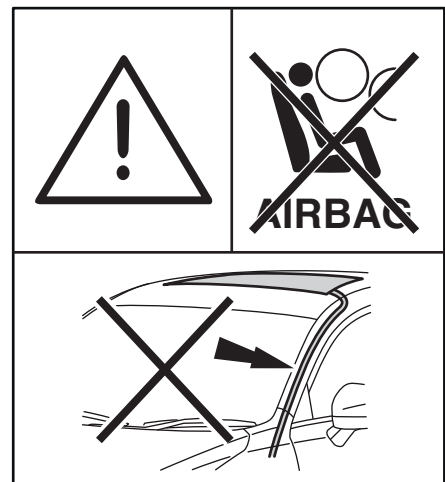

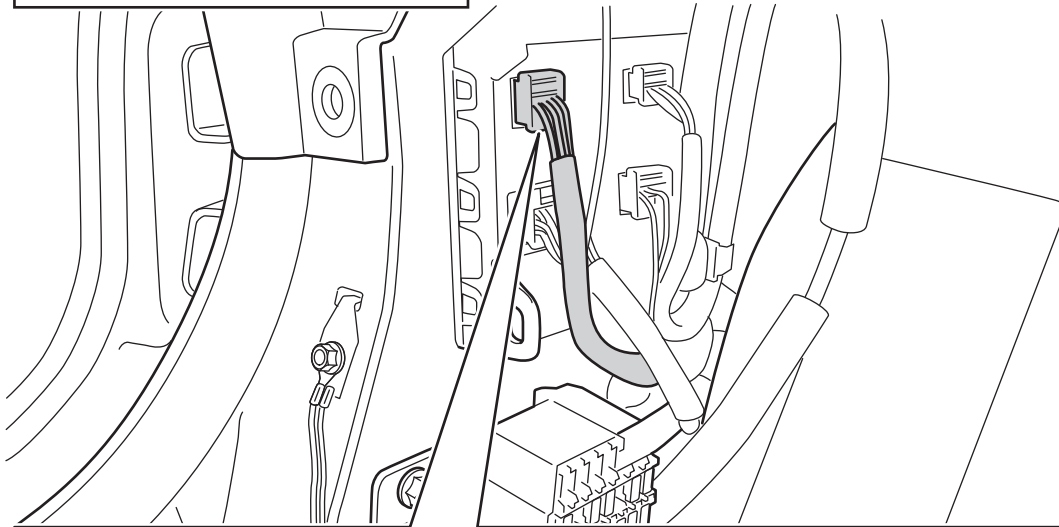
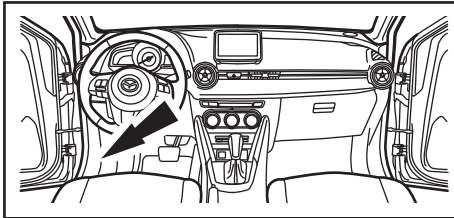
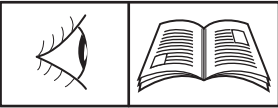

0940-102A

[+12V ignition]

1

2

3

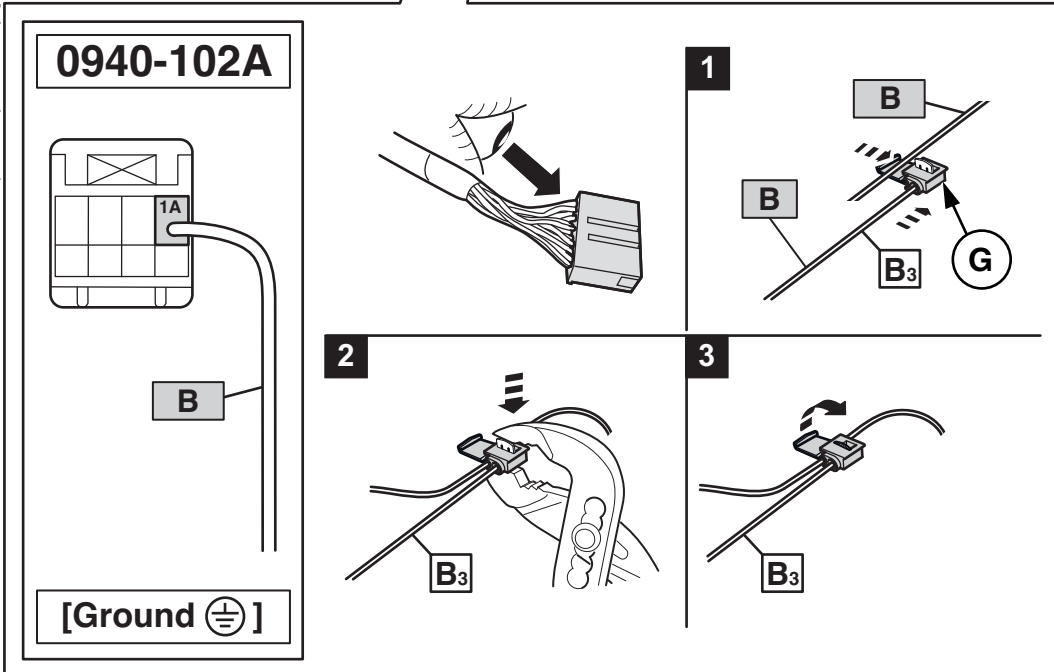
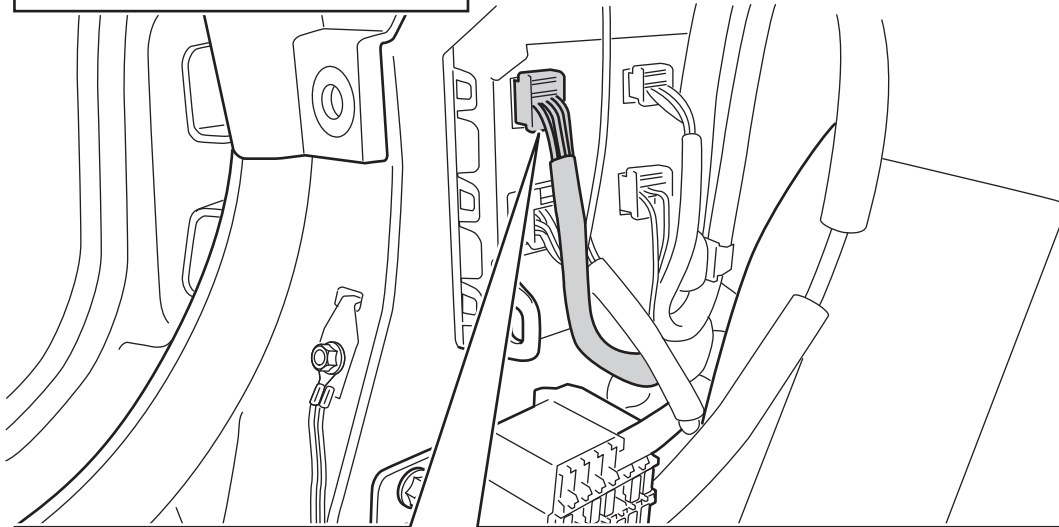
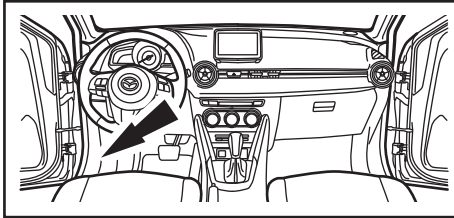
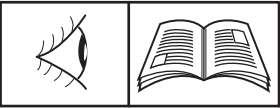

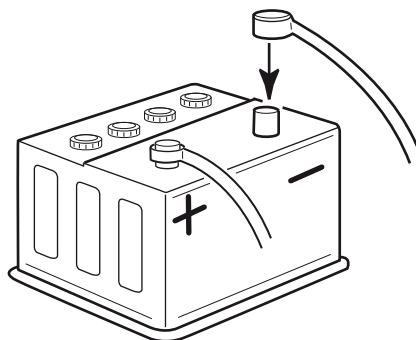
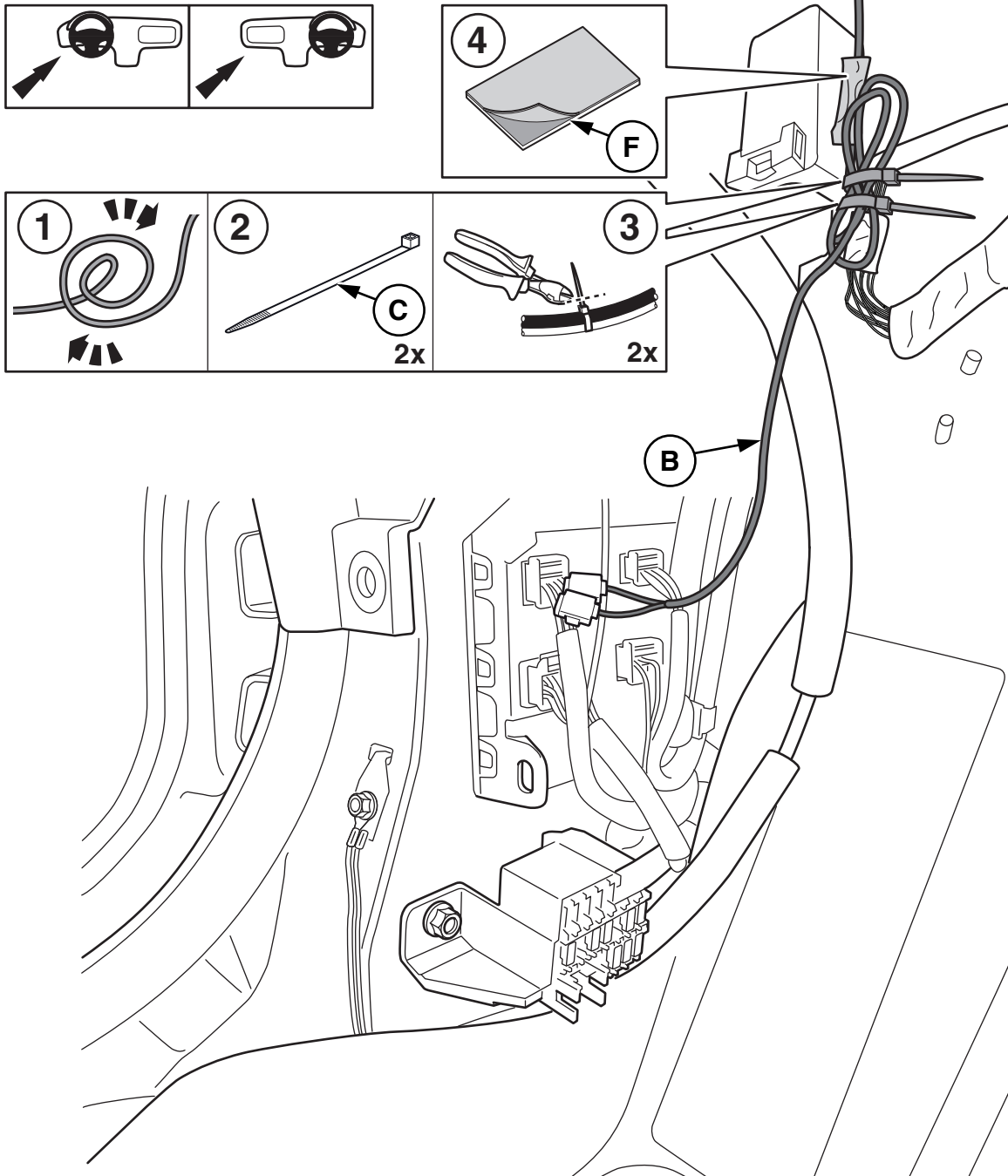

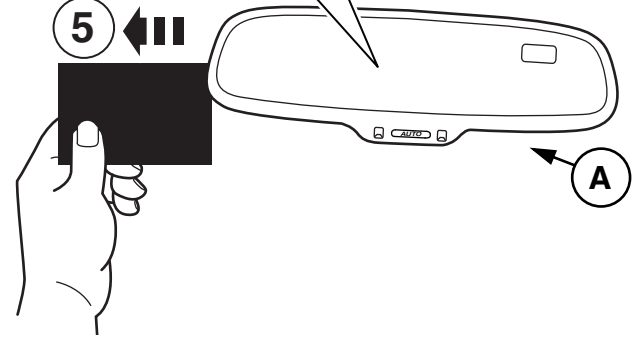
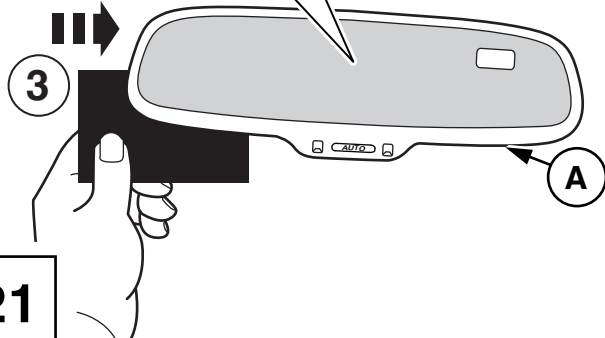
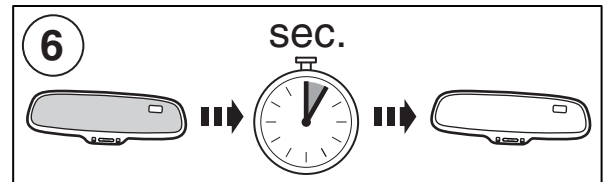
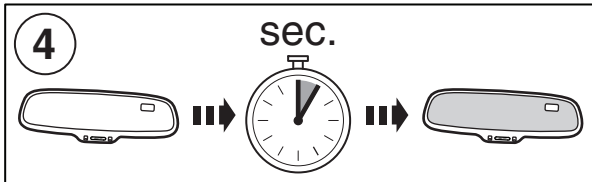
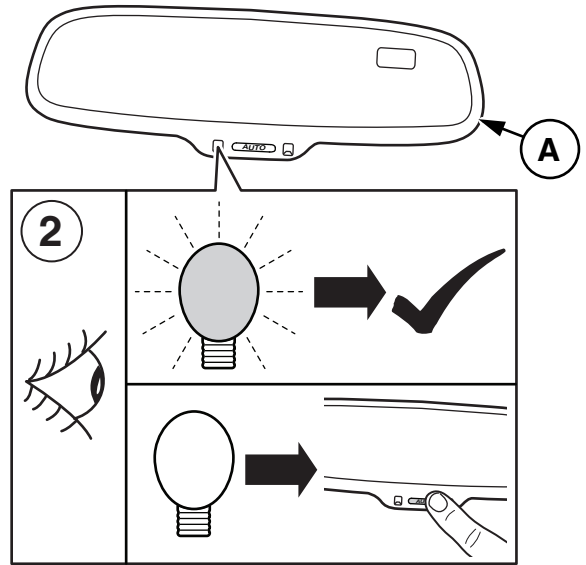

21

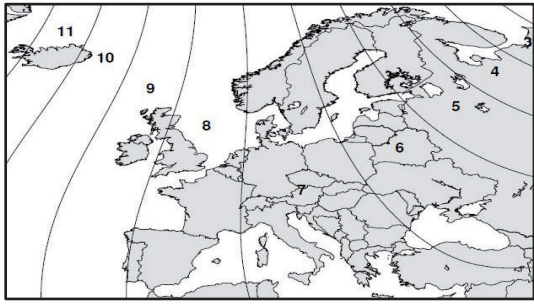

22

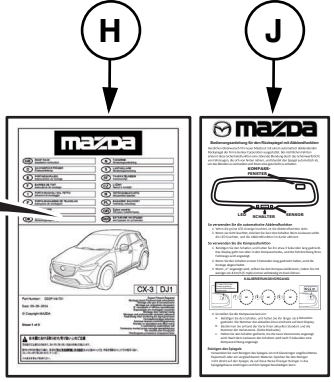
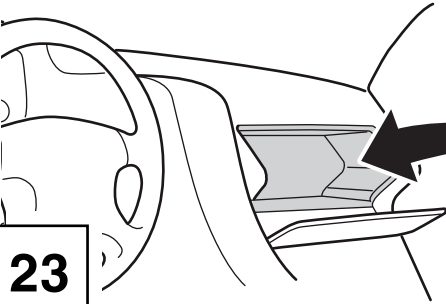

23

Subject to alteration without notice
 Technische Änderungen vorbehalten
 Reservadas modificaciones técnicas
 So Technische wijzigingen voorbehouden
 Med forbehold for tekniske indringer
 Tekniske forendringer forbeholdes
 Med reservation för tekniska ändringar
 Tekniset muutokset pidätetään
 Technické zmeny vyhrazeny
 A változtatások technika jogát fenntartjuk
 Zmiany techniczne zastrzeżone
 Επιφυλασσόμεθα για αλλαγές
 Можно изменять без уведомления